

Dimensions		Unit : mm (ft-in)
Vi017		
A	2200	(7'03")
B	2310	(7'7")
C	1850	(6'1")
D	3710	(12'2")
E	3450	(11'4")
F	1525	(5'0")
G	3690	(12'1")
H	2630	(8'8")
I	1535	(5'0")
J	2300	(7'7")
K	260	(10")
L	950	(3'1")
	1280	(4'2")
M	230	(9")
N	175	(7")
O	125	(5")
P	640	(2'1")
Q	400	(1'4")
R	85	(3")
S	R540	(2'1")

# Vi017

[Gross] 10.1kW (13.7PS)

### Specifications

Model		Vi017	
Type		Canopy	
Operating weight	Rubber track	kg (lbs)	1740 (3836)
	Steel track	kg (lbs)	1800 (3969)
Engine	Type	-	Water-cooled 3 cycle diesel
	Model	-	3TNV70-XBV
	Output	kW (hp) / rpm	10.1 (13.5) / 2200
Performance	Bucket capacity, standard (ISO heaped)	cu.m (cu.ft)	0.05 (1.77)
	Max digging force, bucket / arm	kN (lbf)	15.2 (3417) / 8.5 (1918)
	Traveling speed, high / low	km/h (MPH)	4.3 / 2.1 (2.7 / 1.3)
	Swing speed	RPM	9.5
	Boom swing angle, (L / R)	degrees	42 / 65
Ground contact pressure	Rubber track	kPa (PSI)	28.6 (4.1)
	Steel track	kPa (PSI)	29.6 (4.3)
Hydraulic system	Pump capacity	L / min (GPM)	17.6 + 17.6 + 13.2 + 11.2 (4.6 + 4.6 + 3.5 + 2.6)
	Main relief set pressure	MPa (PSI)	20.6 (2987)
Undercarriage	Track type	-	Rubber
Blade dimensions	Width x height	mm (ft-in)	1260 / 950 x 235 (4'2" / 3'1" x 9")
Fuel tank capacity	L (Gals)	-	20 (5.3)

### Standard Equipment

- Blade
- Boom swing function
- Cylinder cover (boom, arm, bucket, blade)
- Rubber or Steel tracks
- ROPS / FOPS canopy
- Joystick pilot controls
- Arm rests
- Sliding seat
- Seat belt
- Travel levers and pedals
- Floor mats
- Built-in type boom light
- Variable track

Please note that the standard equipment may vary from this list. Consult your Yanmar dealer for confirmation

### Hydraulic P.T.O

Model	Output	Vi017		
		MPa (PSI)	L / min (GPM)	
Specification			2200RPM	1250RPM
Combined flow, double actions		16.7 (2417)	30.8 (8.1)	17.5 (4.6)



## YANMAR CONSTRUCTION EQUIPMENT CO.,LTD.

OVERSEAS SALES DEPT.

MARKETING & SALES DEPT.

1717-1 Kumano, Chikugo, Fukuoka 833-0055, JAPAN

TEL +81-942-53-5465 FAX +81-942-53-5132

yanmar.com

All data subject to change without notice.

# The Mini Excavator, Reinvented by Yanmar

## A Whole Line Up of High Performance Features for Professionals

### True Zero Tail Swing, No Bother at the Rear



Side Ditch Digging up to the Wall without Sticking Out beyond the Track.

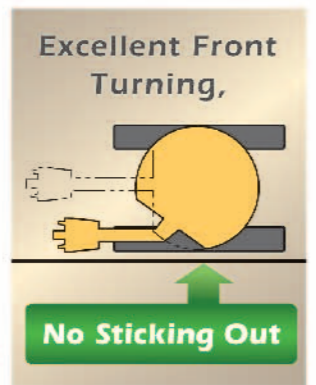

### Yanmar's Unique Variable Undercarriage

Contracted to enter narrow places and extended to ensure stable work.

Yanmar's Mini Excavator allows ease of access to narrow places and ensures stable workability. Besides, the Mini Excavator is of sturdy construction that prevents itself from wobbling when the undercarriages are widely opened.

Moreover, when the distance between the undercarriages is extended, the Mini Excavator forcibly discharges the mud in the sliding pipes, thus performing highly efficient work in any place regardless of the size of the place.

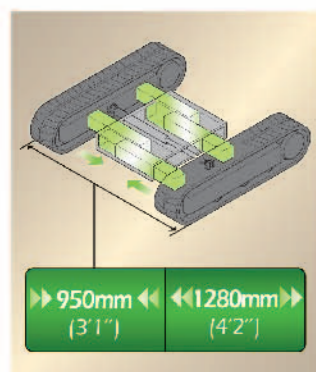

### Extension Blade

Easy to fold.

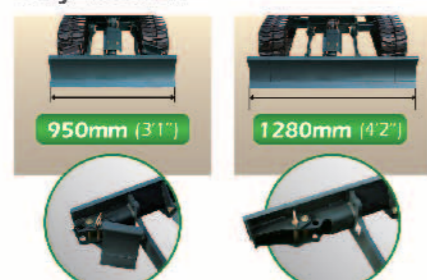

(Sliding type)



### Top-level Work Performance in This Class

The best matching of the hydraulic system of the engine provides extremely high power for this class, thus demonstrating high performance.

Lifting Capacity  
Avg **15% UP**

Bucket Digging Force  
Avg **12% UP**

### 3 Hydraulic Pump System

Fruition of Comfortable Operational Performance with the equivalent level of its upper classes.

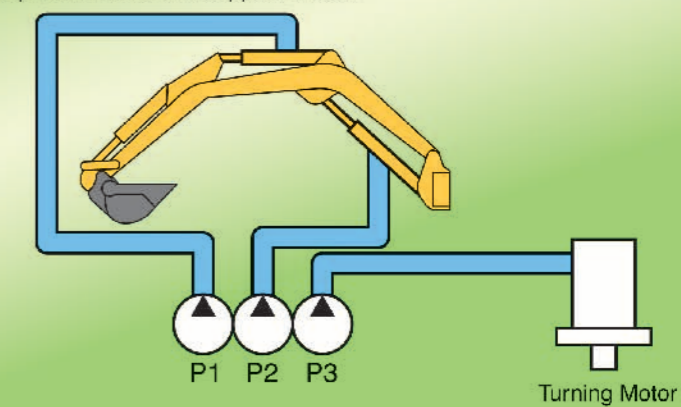

Smooth even while using both the boom and arm during turning!

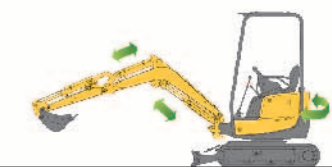

### Incorporates a Rectilinear Running Circuit

The rectilinear running circuit prevents the Mini Excavator from moving zigzag, thus making it possible to operate the working device while the Mini Excavator is running straight.

# YANMAR Originality

# Easy Operation! it's a Joy! All-Round Comfort and Convenience!

## Large Space for Unrestricted Operation

Even a zero tail swing, large operation space of ViO 17 provides easy and unrestricted operating space. It reduces operating stress and fatigue.



## Broad Range of Sight for Safe and Comfortable Operation

The standard, lightweight canopy has ROPS and FOPS to protect the operator in rollovers and from falling objects. No wall hinders the view. Work is safe and efficient.



**Large Traveling Pedal**

Easier & more comfortable operation! Large traveling pedals make it much more easier & more comfortable for your operation.



**Walk-through operating area**

Easy to get on & off. Get on & off from the either side. Walk-through operating area.



**Improvement in Ease of Fueling**

Allows fueling in an easy posture. The fill opening is located in front of the control lever on the right-hand side. The Mini Excavator can be fueled with ease from a polyethylene fuel tank placed on the driver's seat floor.



**External Power Supply (12V)**

Standard fitting. Socket-convenient for charging such as mobile phones or other appliances.



**Safety Lever Mechanism**

Prevents risks resulting from abrupt malfunctions.

- **Neutral Lever Lock**  
The Mini Excavator is provided with safety levers that lock the movement such as operation of the excavating, turning and running of Mini Excavator.
- **Engine Neutral Start Mechanism**  
The engine does not start unless the lever is locked, thus preventing the abrupt movement of the Mini Excavator resulting from malfunctions.



**Wrist control Lever and Arm Rest**

Ensures ease of operation and smooth work. Lever operation from the wrist and the armrest alleviate the fatigue of a long working day.



**Manual Case**

All manuals are right there! The space under the seat accommodates manuals, magazines, and booklets with ease.



**Four-pillar ROPS/FOPS Canopy**

Easier & more comfortable operation! Meets international protection standards to ensure safer work than ever before.  
ROPS: Roll-over Protection System  
FOPS: Falling-object Protection System

# Proven Durability! Ease of Maintenance!

## Simple Engine Access Brings Big Improvements to Maintenance Efficiency



### Daily Inspection

The Mini Excavator allows an engine oil check, engine replenishment, air cleaner cleaning, and water supply to the cooling water sub tank quickly when the rear bonnet is opened.



### Hydraulic Equipment and Return Filter Maintenance

The hydraulic equipment and return filter can be maintained with ease when the left-hand-side cover is removed. The return filter is of cartridge type, which can be replaced easily without dirtying the hands.



### Cell Motor and Generator Maintenance

The battery, cell motor, and generator can be maintained with ease when the cover in front of the driver's seat is opened.



### Fuel Tank and Radiator Maintenance

The fuel tank and radiator can be maintained without any difficulty when the right-hand-side cover is removed.



## Cylinder Guards

The plate spring cylinder guard is resilient against shocks and used to protect the bucket arm & boom cylinder.



## Underside Protector

The frame corners are reinforced with ultra-high strength steel. The side cover has a thicker plate for higher resilience.



## Boom Light Interior Structure

Prevents the working light from damage.



## Blade Cutting Edge

Using the steel which is strong against wearing.



## Lifting Capacity

Excavator equipped with ROPS/FOPS and rubber crawlers (with quick coupler and bucket)

r : Reach from swing center line : mm (in)  
h : Lift point height : mm (in)  
w : Lifting capacity : kg (lbs)  
P : Load point

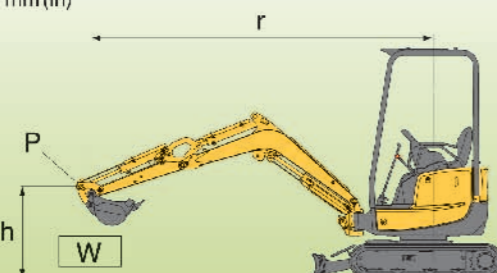
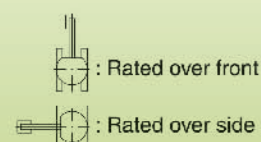

- The rated lifting capacities that are indicated below are based on ISO 10567 and do not exceed 87% of the excavator's hydraulic lifting capacity or 75% of its static tilt load (tipping load) capacity.
- The following operating criteria are also applicable to the calculation of these maximum loads:
  - The "load point" is the location of the front bolt on the arm
  - The three indicated machine position are :
    - arm over the front end (blade down),
    - arm over the front end (blade up), and
    - arm over the side (blade up).
- The weight of the excavator's bucket, hook, sling and other lifting accessories have been taken into consideration when calculating these maximum loads.

LIFT POINT HEIGHT	r : LIFT RADIUS mm (in)					r : LIFT RADIUS mm (in)					r : LIFT RADIUS mm (in)				
	RATED LIFT CAPACITY OVER END BLADE DOWN : kg (lbs)					RATED LIFT CAPACITY OVER END BLADE UP : kg (lbs)					RATED LIFT CAPACITY OVER SIDE BLADE UP : kg (lbs)				
	h : mm (in)	MAX	98.5 (2500)	78.7 (2000)	MIN	MAX	98.5 (2500)	78.7 (2000)	MIN	MAX	98.5 (2500)	78.7 (2000)	MIN		
2000 (78.7)	*340 (749)	*320 (705)			225 (496)	*315 (694)				235 (518)	*315 (694)				
1500 (59.1)	*350 (771)	*370 (815)	*425 (936)		205 (451)	305 (672)	*420 (925)			215 (473)	*370 (815)	*425 (936)			
1000 (39.4)	*365 (804)	*450 (992)	*595 (1311)	665 (1466)	185 (407)	285 (628)	410 (903)	525 (1157)	200 (440)	295 (650)	435 (959)	550 (1212)			
500 (19.7)	*375 (826)	*525 (1157)	*740 (1631)	*920 (2028)	185 (407)	280 (617)	390 (859)	470 (1036)	200 (440)	295 (650)	415 (914)	500 (1102)			
0 (Ground)	*390 (859)	*550 (1212)	*785 (1688)	*1050 (2314)	190 (418)	285 (584)	365 (804)	520 (1146)	205 (451)	285 (628)	385 (848)	495 (1091)			
-500 (-19.7)	*410 (903)	*545 (1201)	*735 (1620)		210 (462)	280 (573)	355 (782)		225 (496)	280 (617)	385 (848)				
-1000 (-39.4)	*420 (925)		*680 (1499)		250 (551)		375 (826)		265 (584)		405 (892)				

Note: The maximum loads marked with an asterisk(\*) were limited by the Excavator's hydraulic lifting capacity rather than by its static tilt load (tipping load) capacity.